

■ Features

- PB Free.
- Mono-color type.
- 1206 Package in 8 mm tape on 7” diameter reels.
- Suitable for all SMT assembly methods.
- Compatible with automatic placement equipment.
- Compatible with infrared and vapor phase reflow solder process.

■ Typical Applications

- Automotive: Dashboards, stop lamps, turn signals.
- Backlighting: LCDs, Key pads advertising.
- Status indicators: Consumer & industrial electronics.
- General use.

■ Package Dimensions

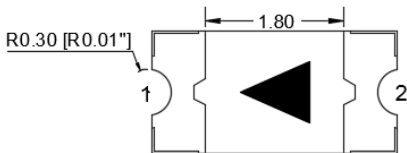
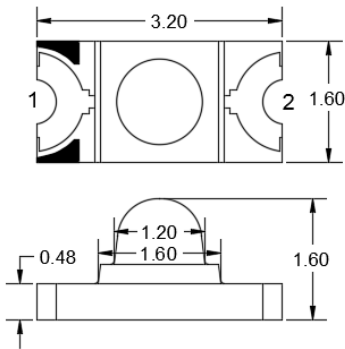

Recommend Pad Layout

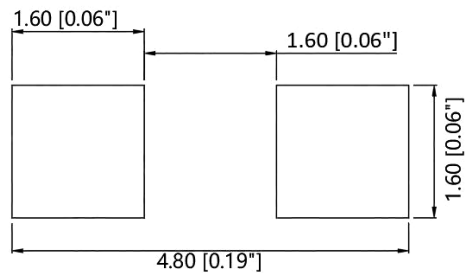

Notes:

1. All dimensions are in millimeters (inches).
2. Tolerance is $\pm 0.10\text{mm}$ ($0.004'$) unless otherwise specified.

■ Device Selection Guide

Chip Material	Emitted Color	Lens Color
AllnGaP	Red	Water Clear

■ Absolute Maximum Ratings at Ta=25°C

Parameter	Symbol	Maximum	Unit
Power Dissipation	Pd	72	mW
Peak Forward Current (Duty 1/10 @1KHz)	I _{FP}	100	mA
Forward Current	I _F	30	mA
Reverse Voltage	V _R	5	V
Operating Temperature Range	Topr	-40°C to + 85°C	
Storage Temperature Range	Tstg	-40°C to + 100°C	
Lead Soldering Temperature [2.0mm from body]	Tsol	Preheating: 140°C~160°C±5°C, within 2 minutes. Operation heating:260°C(Max) within 10 seconds.(Max) Gradual Cooling (Avoid quenching).	

■ Electrical/Optical Characteristics at Ta=25°C

Parameter	Symbol	Test Condition	Min.	Typ.	Max.	Unit
Luminous Intensity	I _v	I _F =20mA	800	1600	—	mcd
Dominant Wavelength	λ _d	I _F =20mA	620	—	630	nm
Forward Voltage	V _F	I _F =20mA	1.8	—	2.4	V
Viewing Angle	2θ _{1/2}	I _F =20mA	—	30	—	deg
Reverse Current	I _R	V _R =5V	—	—	10	uA

Notes:

1. Tolerance of Luminous Intensity ±15%.
2. Tolerance of Forward Voltage ±0.1V.
3. Tolerance of Dominant Wavelength ±1nm.

■ Typical Electrical/Optical Characteristic Curves

(25°C Ambient Temperature Unless Otherwise Noted)

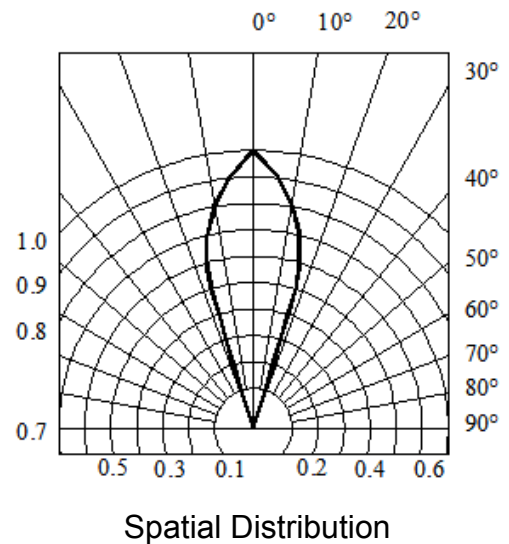
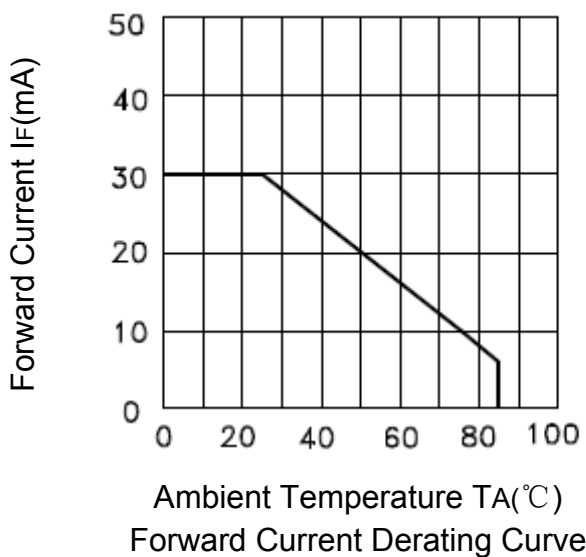
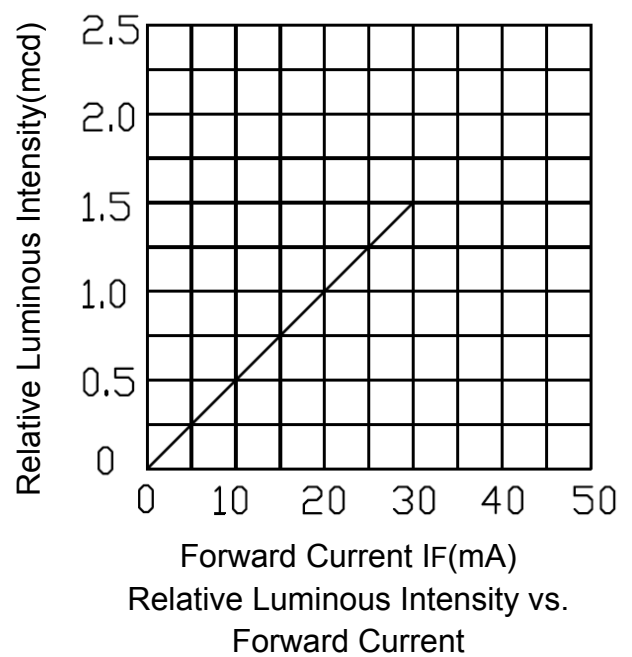
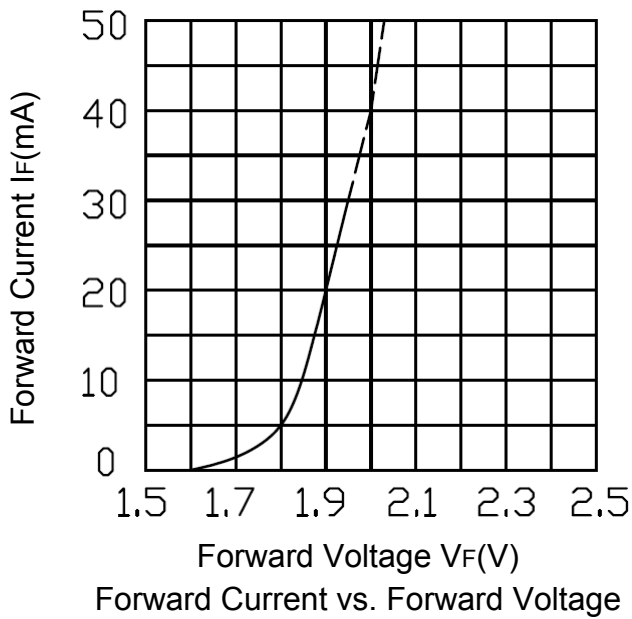
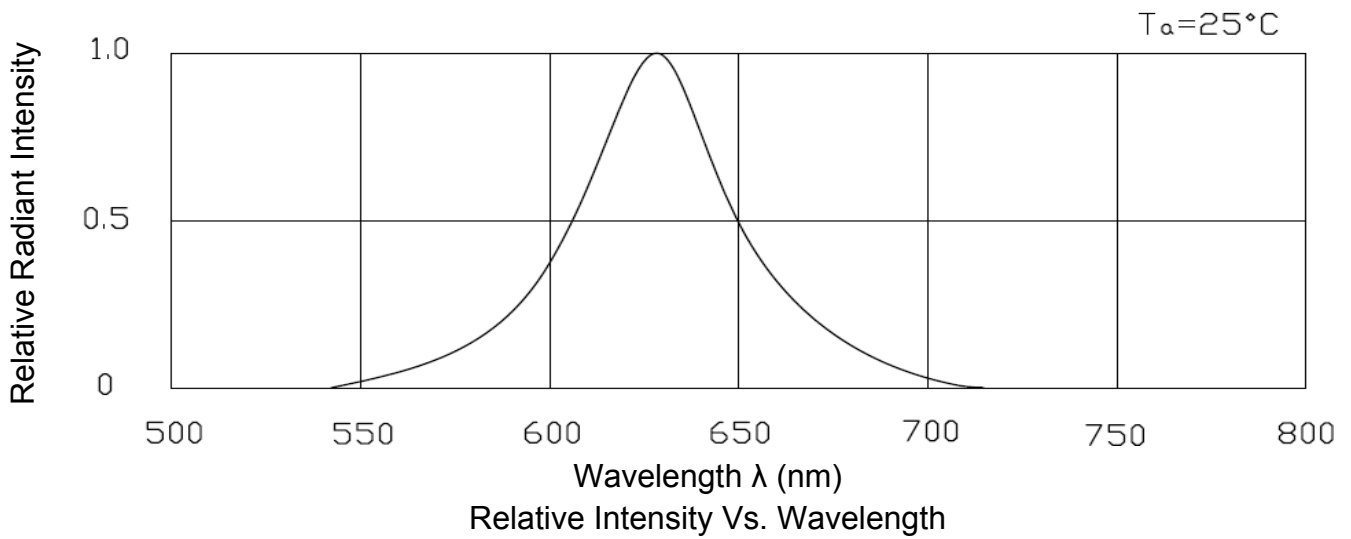

■ Precautions

1. Storage

- Recommend storage environment
Temperature: 5°C~30°C (41°F~86°F) Relative Humidity: 60% RH Max.
- Product in the original sealed package is recommended to be assembled within 168 hours of opening.
- If the moisture absorbent material (silica gel) has faded away or the LEDs have exceeded the storage time, baking treatment should be performed using the following conditions.
 - a. Baking treatment: 60±5°C for 24 hours.
 - b. Fold the opened bag firmly and keep in dry environment.

2. Cleaning

- Surface condition of this device may change when organic solvents such as trichloroethylene or acetone were applied.
- Avoid using organic solvent.
- Recommend ultrasonic method 300W Max.

■ SMT Reflow Soldering Temp/Time

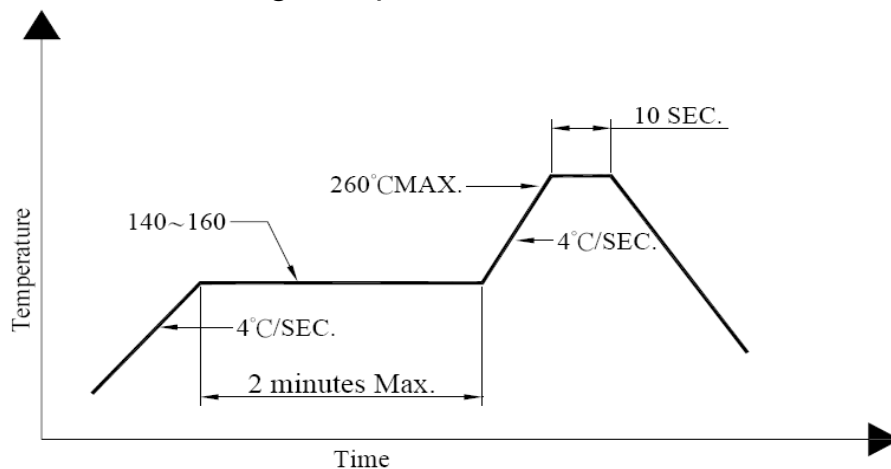

■ Reflow soldering

- Recommend use of upper and lower heater type reflow furnace.
- 260°C Max for up to 10 seconds, one time only.
- Pre-heat is 150°C Max for up to 2 minutes Max.
- In case of screen-printing, keep metal mask thickness between 0.2mm and 0.3mm.
- When soldering, do not put stress on the LEDs during heating.

■ Soldering iron

- When hand soldering, keep the temperature of iron below less 300°C less than 3 seconds.
- The hand solder should be done only one times.

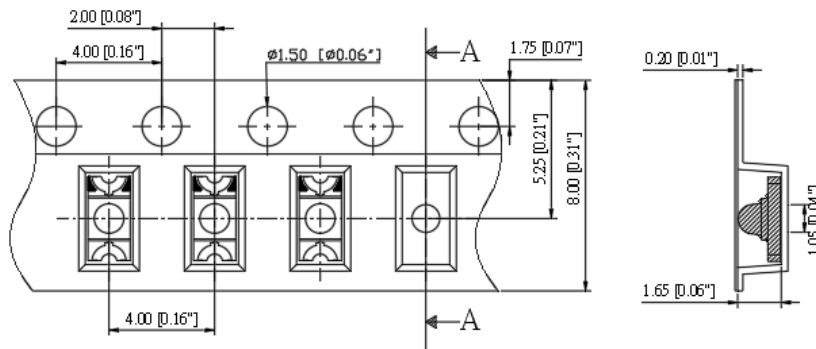
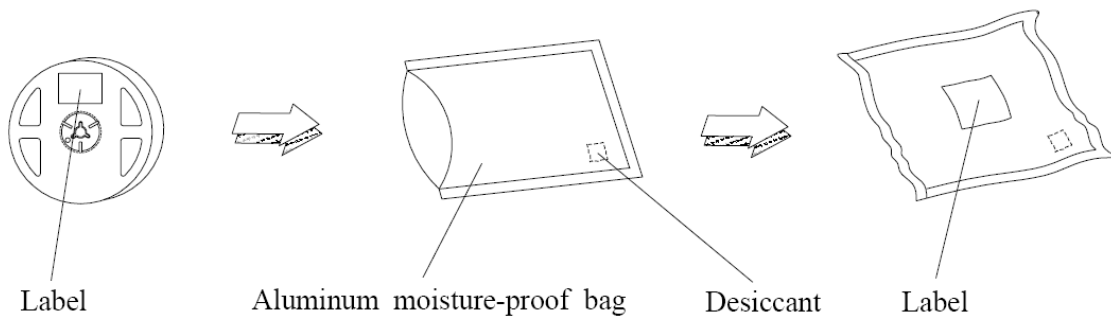
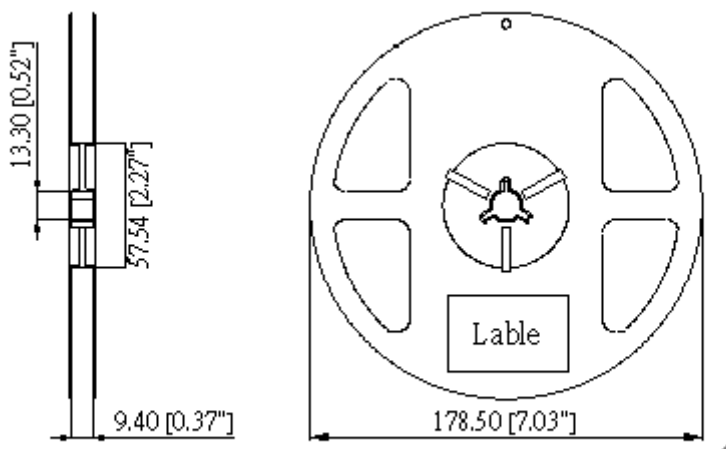
Carrier Tape Dimensions: Loaded quantity 3000 PCS per reel.**Moisture Resistant Packaging****Reel Dimensions****Notes:**

1. All dimensions are in mm, tolerance is ± 2.0 mm unless otherwise noted.
2. Specifications are subject to change without notice.